

1

FLANGE - STAINLESS STEEL - AX/F Ø (Supplied with screws)

Ø	D H11	FB H13	E	MF JS14	R JS14	TF JS14	UF
32	30	7	45	10	32	64	80
40	35	9	52	10	36	72	90
50	40	9	65	12	45	90	110
63	45	9	75	12	50	100	120
80	45	12	95	16	63	126	150
100	55	14	115	16	75	150	170

Ø	W	ZF	WEIGHT (g)
32	16	130	190
40	20	145	246
50	25	155	478
63	25	170	622
80	30	190	1430
100	35	205	1986

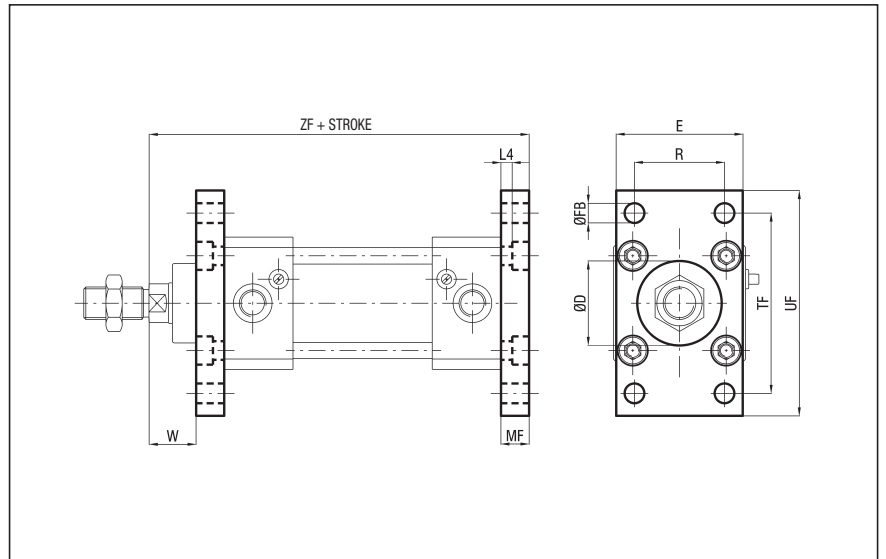

FOOT - STAINLESS STEEL - AX/PB Ø (Supplied with screws)

Ø	AB H14	AH JS15	AT	AU	E	F	SA
32	7	32	4	24	45	35	142
40	9	36	4	28	52	36	161
50	9	45	5	32	65	47	170
63	9	50	5	32	75	45	185
80	12	63	6	41	95	55	210
100	14	71	6	41	115	57	220

Ø	TR JS14	XA	WEIGHT (g)
32	32	144	66
40	36	163	78
50	45	175	168
63	50	190	190
80	63	215	382
100	75	230	452

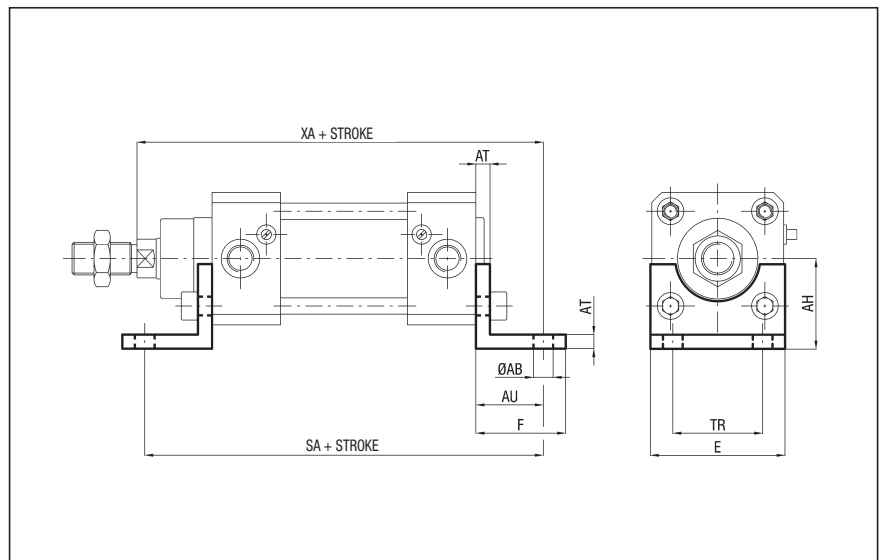

Accessories
**Stainless steel fixings for
 cylinders to ISO 15552 standard**

series **AX**

1

REAR FEMALE HINGE - STAINLESS STEEL - AX/CF Ø (Supplied with screws)

Ø	CB H14	CD H9	E	FL	L	L4	UB h14
32	26	10	45	22	13	5,5	45
40	28	12	52	25	16	5,5	52
50	32	12	65	27	16	6,5	60
63	40	16	75	32	21	6,5	70
80	50	16	95	36	22	10	90
100	60	20	115	41	27	10	110
125	70	25	140	50	30	10	130

Ø	XD	WEIGHT (g)
32	142	138
40	160	230
50	170	338
63	190	540
80	210	1000
100	230	1700
125	275	3350

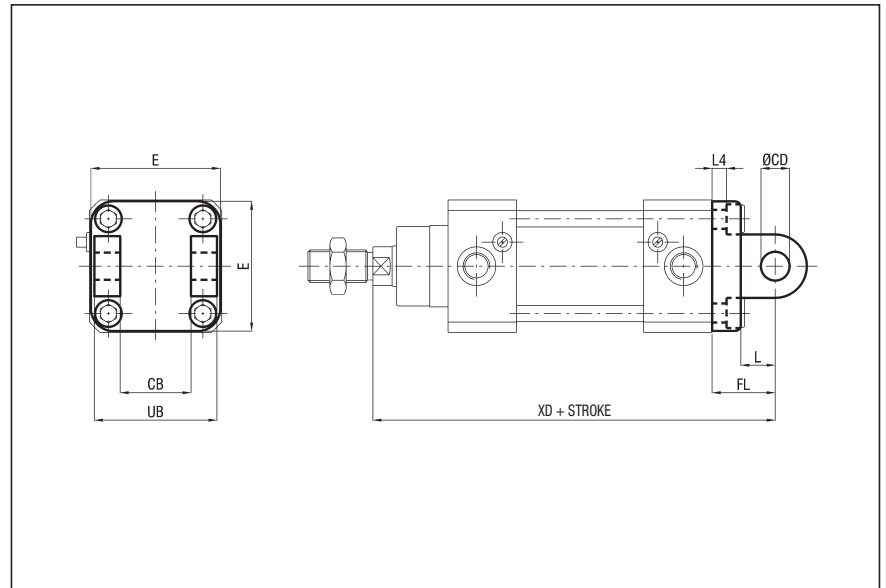

PIVOT FOR REAR FEMALE HINGE - STAINLESS STEEL - AX/SEC Ø

Ø	BU	EK f7	EL	WEIGHT (g)
32	53	10	46	32
40	60	12	53	52
50	68	12	61	60
63	78	16	71	122
80	98	16	91	152
100	118	20	111	290
125	139	25	132	530

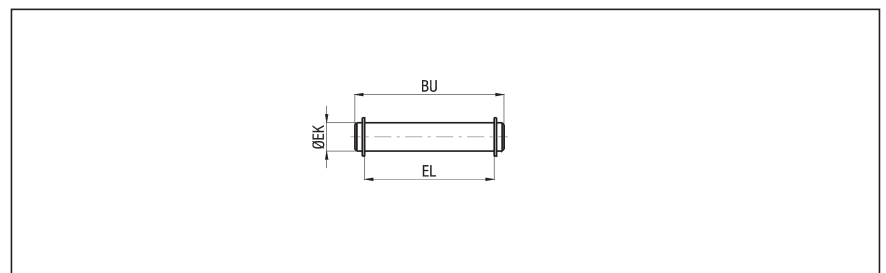

REAR MALE HINGE - STAINLESS STEEL - AX/CM Ø

Ø	CD H9	E	EW	FL	L	L4	XD
32	10	45	26	22	13	5,5	142
40	12	52	28	25	16	5,5	160
50	12	65	32	27	16	6,5	170
63	16	75	40	32	21	6,5	190
80	16	95	50	36	22	10	210
100	20	115	60	41	27	10	230
125	25	140	70	50	30	10	275

Ø	WEIGHT ALL. (g)
32	138
40	230
50	338
63	540
80	1000
100	1700
125	3350

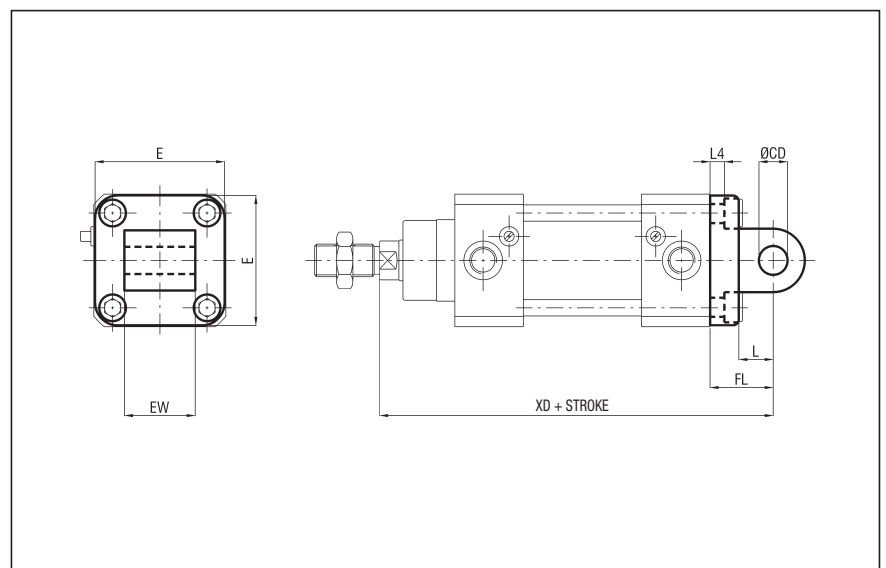

1

SQUARE JOINT - STAINLESS STEEL - AX/AS Ø

Ø	PH JS15	CK H9	EM	GL JS14	RA JS14	UR	BT	L5
32	32	10	26	21	18	31	8	1,6
40	36	12	28	24	22	35	10	1,6
50	45	12	32	33	30	45	12	1,6
63	50	16	40	37	35	50	14	1,6
80	63	16	50	47	40	60	14	2,5
100	71	20	60	55	50	70	17	2,5
125	90	25	70	70	60	90	20	3,2

Ø	BR	S5 H13	K1 JS14	K2	XD	WEIGHT (g)
32	10	6,6	38	51	142	158
40	11	6,6	41	54	160	238
50	13	9	50	65	170	418
63	15	9	52	67	190	526
80	15	11	66	86	210	1055
100	19	11	76	96	230	1360
125	22,5	14	94	124	275	3150

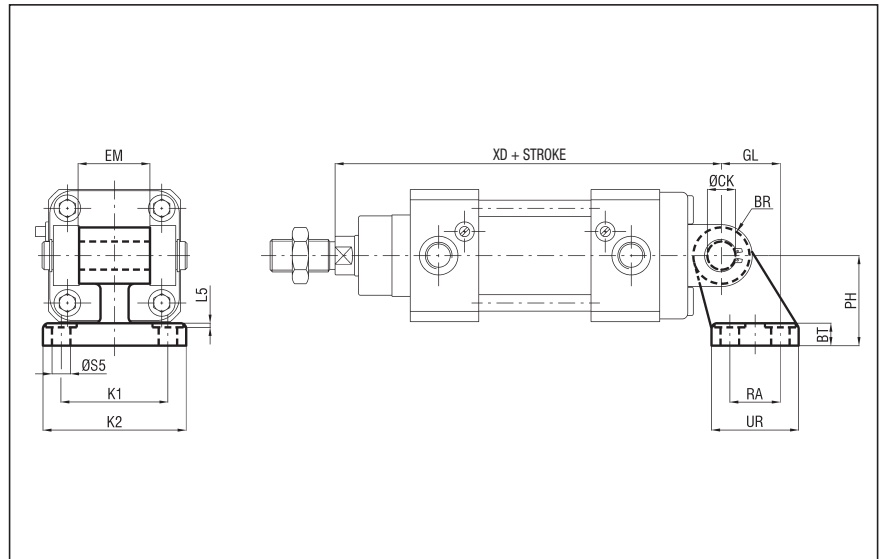

NARROW REAR FEMALE HINGE - STAINLESS STEEL - AX/CFS Ø (Supplied with screws)

Ø	CG D10	CP d12	B3	ØCF F7	E	FM	L10	L11
32	14	34	3,3	10	45	22	9	16,5
40	16	40	4,3	12	52	25	9	18
50	21	45	4,3	16	65	27	11	22
63	21	51	4,3	16	75	32	11	22
80	25	65	4,3	20	95	36	14	26
100	25	75	6,3	20	115	41	14	26
125	37	97	6,3	30	140	50	20	39

Ø	L4	XD	WEIGHT (g)
32	5,5	142	140
40	5,5	160	230
50	6,5	170	336
63	6,5	190	546
80	10	210	1190
100	10	230	1840
125	10	275	3550

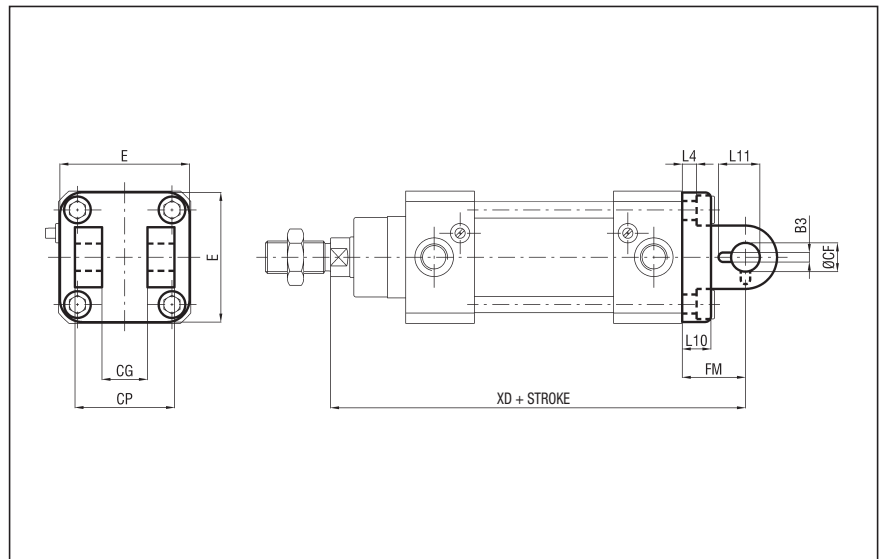

NON-ROTATING PIVOT FOR NARROW REAR FEMALE HINGE - STAINLESS STEEL - AX/SEC Ø AT

Ø	d4 H12	ØJK f7	L8	ES	L9	L5	G	WEIGHT (g)
32	3	10	14	32,5	4,5	41	4	26
40	4	12	16	38	6	48	4	42
50	4	16	20	43	6	54	5	84
63	4	16	20	49	6	60	5	94
80	4	20	24	63	6	75	6	184
100	4	20	34	73	6	85	6	208
125	6	30	36	94	9	110	7	606

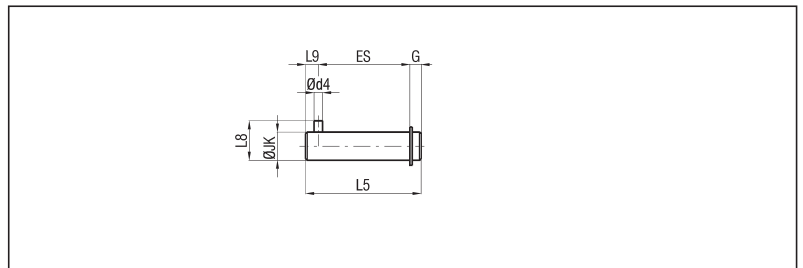

Accessories
**Stainless steel fixings for
 cylinders to ISO 15552 standard**

series **AX**

1

NARROW MALE HINGE WITH ARTICULATED HEAD (ISO 12240) - STAINLESS STEEL - AX/CMSS Ø
 (Supplied with screws)

Ø	ØCX H7	E	EN	MS	EU	G	DL
32	10	45	14	16	10,5	9	22
40	12	52	16	19	12	9	25
50	16	65	21	21	15	11	27
63	16	75	21	24	15	11	32
80	20	95	25	28,5	18	14	36
100	20	115	25	30	18	14	41
125	30	140	37	40	25	20	50

Ø	L4	XD	WEIGHT (g)
32	5,5	142	158
40	5,5	160	254
50	6,5	170	360
63	6,5	190	588
80	10	210	1118
100	10	230	1810
125	10	275	3500

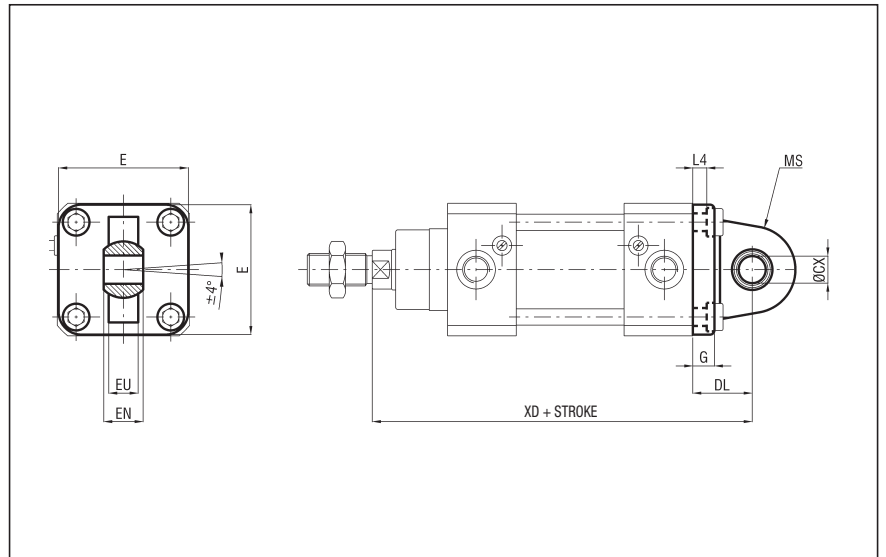

SQAURE JOINT WITH ARTICULATED HEAD (ISO 12240) - STEEL - AX/ASSS Ø

Ø	CA JS15	BQ	CK H7	EM	G1 JS14	G2 JS14	G3	H6
32	32	10,5	10	14	21	18	31	10
40	36	12	12	16	24	22	35	10
50	45	15	16	21	33	30	45	12
63	50	15	16	21	37	35	50	12
80	63	18	20	25	47	40	60	14
100	71	18	20	25	55	50	70	15
125	90	25	30	37	70	60	90	20

Ø	K1 JS14	K2	L5	R	S5 H13	XD	WEIGHT (g)
32	38	51	1,6	15	6,6	142	178
40	41	54	1,6	18	6,6	160	268
50	50	65	1,6	20	9	170	458
63	52	67	1,6	23	9	190	550
80	66	86	2,5	27	11	210	970
100	76	96	2,5	30	11	230	1326
125	94	124	3,2	40	13,5	275	3000

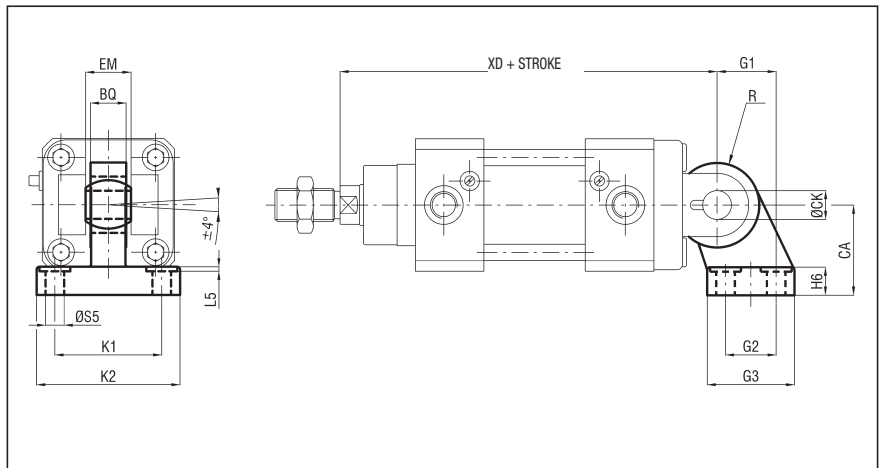

INTERMEDIATE HINGE - STAINLESS STEEL - AX/CTA Ø (Supplied with dowels)

Ø	TK e9	TD h14	TL h14	TM	UW	XV min	XV max	WEIGHT (g)
32	15	12	12	50	46	63,5	82,5	110
40	20	16	16	63	59	73	92	290
50	20	16	16	75	69	80,8	99,2	330
63	25	20	20	90	84	87,5	107,5	650
80	25	20	20	110	102	98,3	121,7	830
100	30	25	25	132	125	109,5	130,5	1560

P.S.:
 - ADJUSTABLE POSITION
 (Fixings with dowels)

ASSEMBLY:
 AX/CTA Ø + cylinder series AX + M/AX/CTA Ø

