

2/2-Way Valve - Type PGV Series 300 - Pressure Operated (Volume Booster) by External Medium

Price group 53	Function "B" normally open (without control pressure)	low noise and impact-free closing, for neutral, gaseous and fluids	Brass
-----------------------	---	--	--------------

Version		Control pressure [bar]	DN	Kv-value water [m³/h]	G	PN	Sealing material	Type	Order number	Price
	2/2-way valve pressure operated, double-sided blocking by external medium Permitted operating pressure 0.3 to 16 bar	\geq excess operating pressure max. 16 bar	13	3.2	G 1/2	16	NBR	PGV-331-B76-1/2BP	614101	o. r.
			13	3.2	G 1/2	16	EPDM	PGV-331-B76-1/2PP	614103	o. r.
			13	3.2	G 1/2	16	FKM	PGV-331-B76-1/2FP	614105	o. r.

Illustration

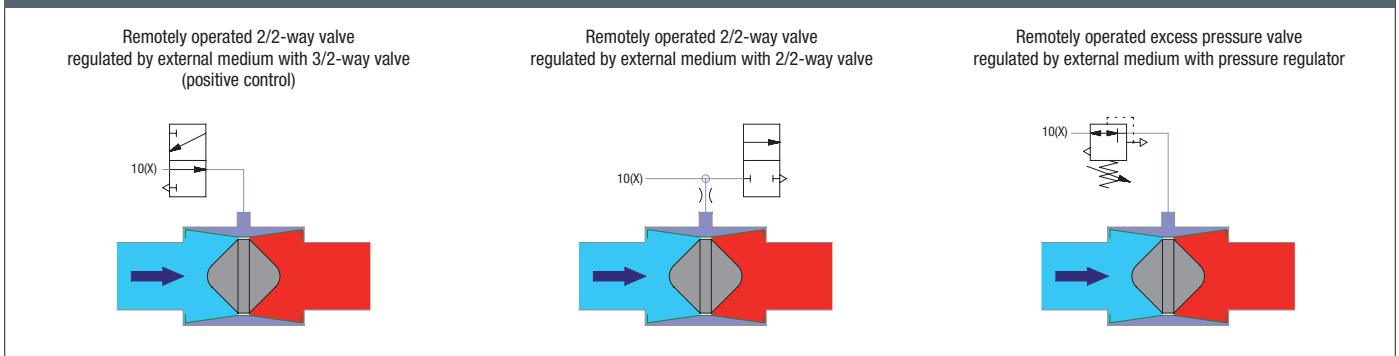

2/2-Way Valve - Type PGV Series 300 - Pressure Operated (Volume Booster) by own Medium

Price group 53	Function "B" normally open (without control pressure)	low noise and impact-free closing, for neutral, gaseous and fluids	Brass
-----------------------	---	--	--------------

Version		Control pressure [bar]	DN	Kv-value water [m³/h]	G	PN	Sealing material	Type	Order number	Price
	2/2-way valve pressure operated by own medium Permitted operating pressure 0.3 to 16 bar	\geq excess operating pressure max. 16 bar	13	3.2	G 1/2	16	NBR	PGV-331-B76-1/2BN	614151	o. r.
			13	3.2	G 1/2	16	EPDM	PGV-331-B76-1/2PN	614153	o. r.
			13	3.2	G 1/2	16	FKM	PGV-331-B76-1/2FN	614155	o. r.

Illustration

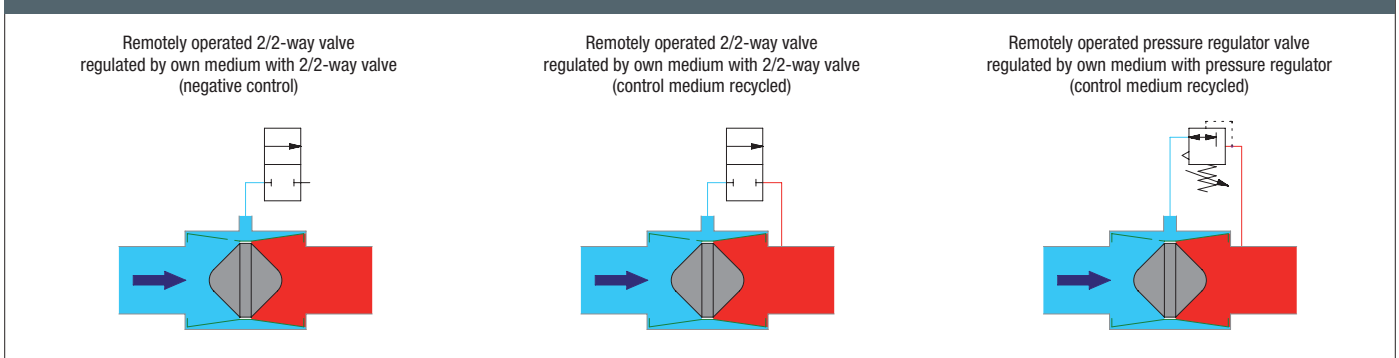

Illustration

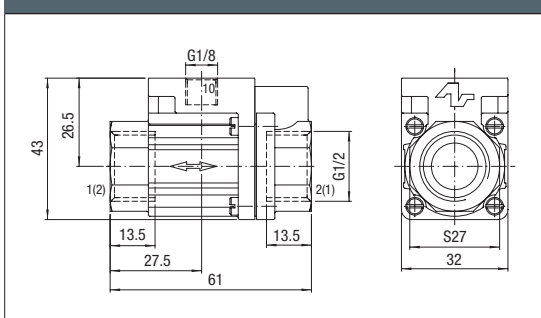

Variations

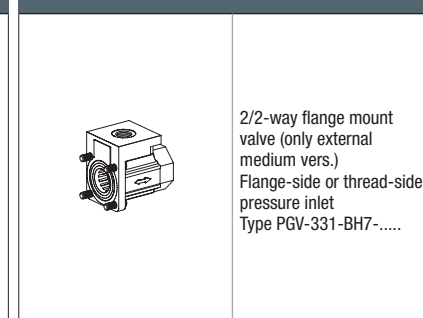

Options

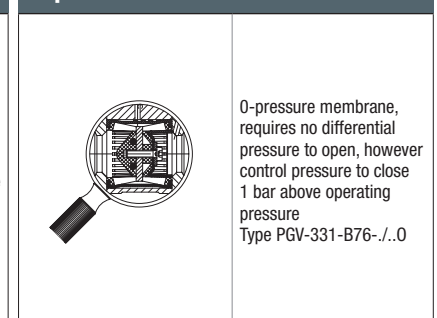

Pressure Regulator Valve - Type RGV Series 300

Price group 53	with secondary side ventilation	low noise and impact-free control, for neutral, gaseous medium (optional fluids)	Amb. temp. $T_{min} -20\text{ °C}$, $T_{max} +60\text{ °C}$ Med.-Temp. $T_{min} 0\text{ °C}$, $T_{max} +60\text{ °C}$	Brass
-----------------------	---------------------------------	--	--	--------------

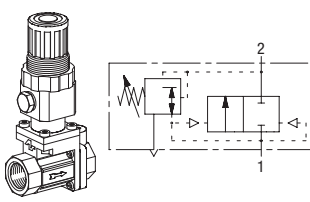
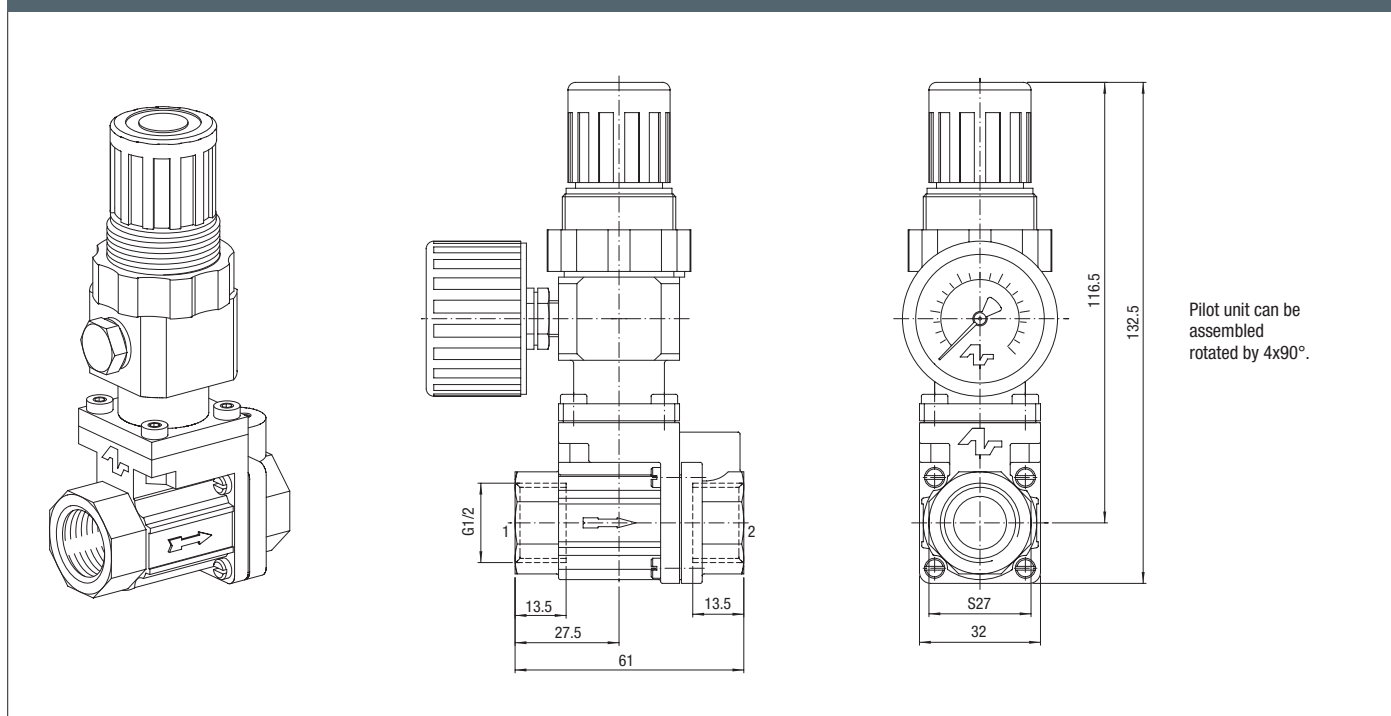
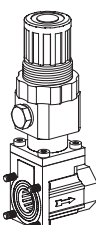

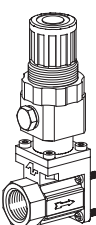
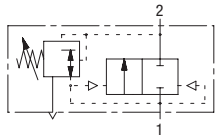
Version	Secondary pressure [bar]	DN	Flow air [l/min]	G	PN	Sealing material	Type	Order number	Price
 <p>Pressure regulator valve without pressure gauge Permitted operating pressure 0.5 bar up to 16 bar</p>	0.5 - 10	13	150 to 1,500	G 1/2	16	NBR	RGV-351-1C78-1/2BN	653001	o. r.
	0.5 - 3	13	150 to 1,500	G 1/2	16	NBR	RGV-351-3C78-1/2BN	653002	o. r.
	0.5 - 6	13	150 to 1,500	G 1/2	16	NBR	RGV-351-6C78-1/2BN	653003	o. r.

Illustration

Variations

	Flange mount Pressure regulator valve Flange-side pressure inlet Type RGV-351-.CH9-....		increases resistance to corrosion, and replaces stainless steel valves cost-effectively stainless steel pressure regulator Type RGV-351Q-...
	Flange mount Pressure regulator valve Thread-side pressure inlet Type RGV-351-.C7L-....		without secondary side ventilation of the pilot pressure regulator, especially for fluids Type RGV-351-.A78-...