

DESCRIPTION

Valves series "EK" are produced in the 3/2, 5/2 and 5/3 pneumatic functions; the kind of construction is based on a balanced spool. In the mechanically actuated version these valves are available only for the size G 1/8 and G 1/4, while the manually actuated versions are available in the different sizes and they are suitable for panel mounting (except for size G 1/2).

TECHNICAL DATA

Operating pressure	0 ÷ 10 bar 3 ÷ 10 bar
Working temperature	0 ÷ +60 °C (con aria secca -20 °C)
Fluid	Filtered, unlubricated or continuous lubricated compressed air
Port size	G 1/8 - G 1/4 - G 1/2
Nominal diameter	G 1/8 = 5 mm G 1/4 = 8 mm G 1/2 = 12 mm
Controls	
Mechanical	Plunger; roller lever; whisker; released pressure key
Manual	Drawer; front lever; lateral knob; actuators for panel mounting (see on page 3.6)

SPARE PARTS

SEALS KIT	
3 port G 1/8	EK/M/SG/8
5 port G 1/8	EKCA/M/SG/8
3 port G 1/4	EK/M/SG/4
5 port G 1/4	EKCA/M/SG/4
5 port G 1/2	EKCA/M/SG/2

FLOW CHART - EK G 1/8 - 5/2

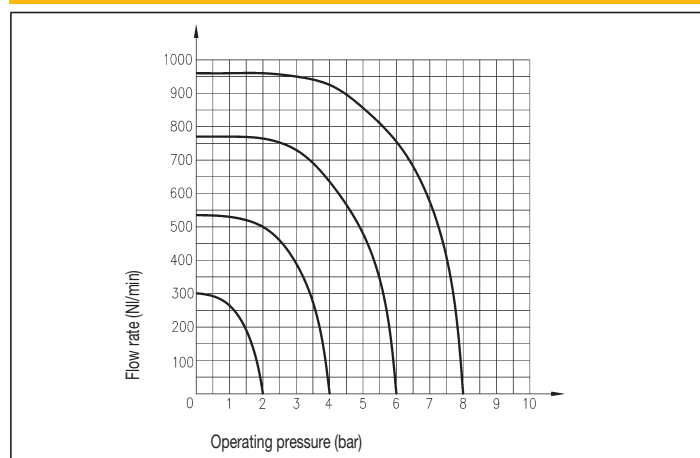

FLOW CHART - EK G 1/2 - 5/2

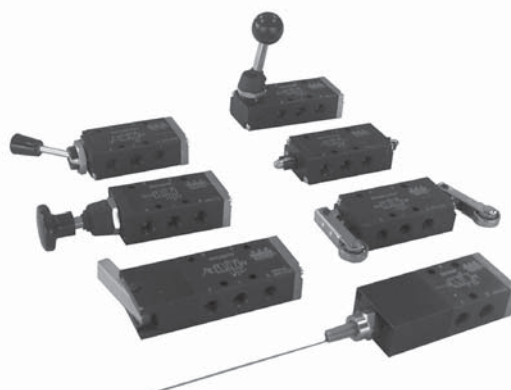
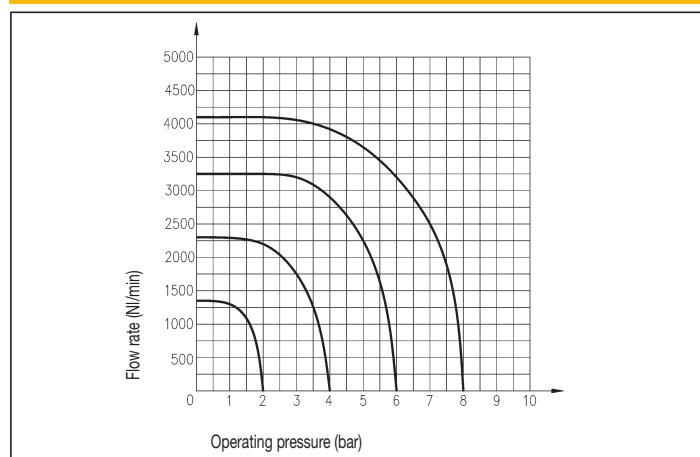

MATERIALS

Bottoms	Front: aluminium alloy or plastic - Rear: aluminium alloy
Body	Anodized aluminium alloy
Distance rings	Acetal resin
Springs	Galvanized steel
Seals	NBR rubber
Spool	Anodized aluminium alloy
Controls	
Lever; Ball	Steel
Whisker	Stainless steel
Released pressure key	Anodized aluminium alloy
Plunger	Brass
Bellows	Elastomer
Knobs; Handgrips	Plastic material
Roller	Ball bearing (plastic material upon request)

FLOW CHART - EK G 1/4 - 5/2

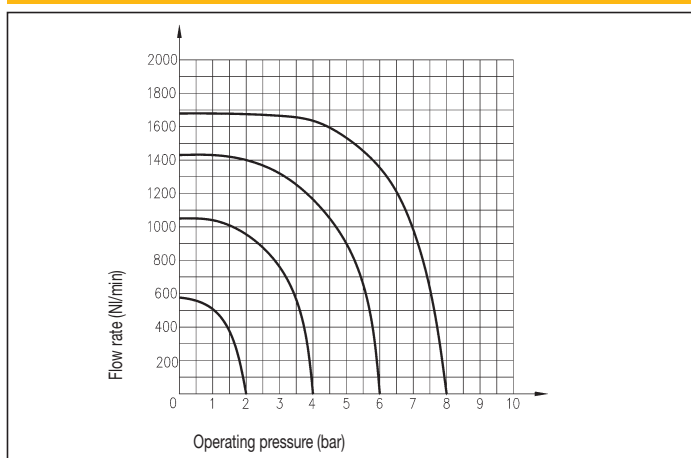

MECHANICALLY ACTUATED VALVES G 1/8

Symbol	Function	Controls		Actuation force at 6 bar (N)	Flow rate at 6 bar ΔP = 1 bar (NI/min)	Weight (g)	TYPE
		Pilot	Return				
	3/2 N.O. monostable	Plunger	Mechanical spring	32	390	135	EK8/PS
	3/2 N.C. monostable						
	3/2 bistable	Plunger	Plunger	32	390	140	EK8/PSS
	5/2 monostable	Plunger	Mechanical spring	32	490	165	EKCA8/PS
	5/2 bistable	Plunger	Plunger	32	490	170	EKCA8/PSS
	3/2 N.O. monostable	Roller lever	Mechanical spring	15	390	160	EK8/LR*
	3/2 N.C. monostable						
	3/2 bistable	Roller lever	Roller lever	15	390	200	EK8/LRLR*
	5/2 monostable	Roller lever	Mechanical spring	15	490	190	EKCA8/LR*
	5/2 bistable	Roller lever	Roller lever	15	490	225	EKCA8/LRLR*
	3/2 N.O. monostable	Piloted whisker (sensitive)	Mechanical spring	1,5	420	230	EKA8/A
	3/2 N.C. monostable						EKC8/A
	5/2 monostable	Piloted whisker (sensitive)	Mechanical spring	1,5	490	260	EKCA8/A
	3/2 N.O. monostable	Piloted released pressure key (sensitive)	Mechanical spring	1,5	420	210	EKA8/TD
	3/2 N.C. monostable						EKC8/TD
	5/2 monostable	Piloted released pressure key (sensitive)	Mechanical spring	1,5	490	230	EKCA8/TD
	3/2 N.O. monostable	Piloted plunger for panel mounting (sensitive)	Mechanical spring	1,5	420	230	EKA8/Q
	3/2 N.C. monostable						EKC8/Q
	5/2 monostable	Piloted plunger for panel mounting (sensitive)	Mechanical spring	1,5	490	260	EKCA8/Q

* - ADD THE LETTER "U" TO THE TYPE TO ORDER THE UNIDIRECTIONAL ROLLER VALVES - E.G.: EKCA8/LRLRU
 - ADD THE LETTER "N" TO THE TYPE TO ORDER THE VALVES WITH PLASTIC ROLLER - E.G.: EK8/LRN

3

EK8/PS

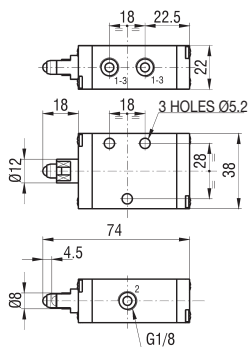

EK8/PSS

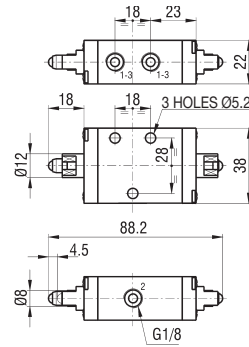

EKCA8/PS

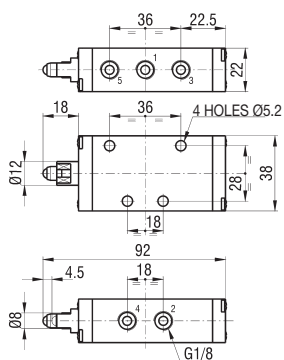

EKCA8/PSS

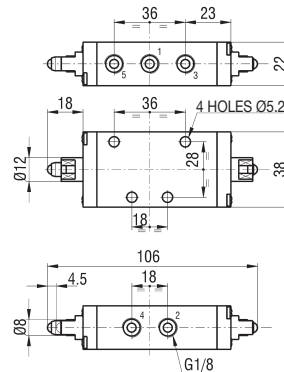

EK8/LR*

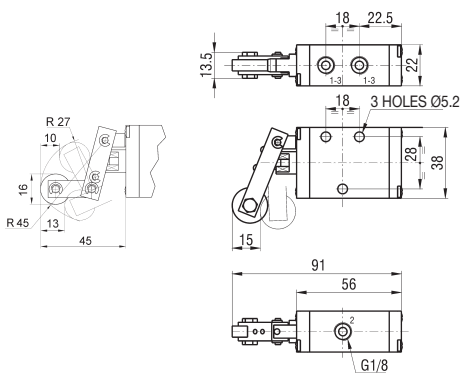

EK8/LRLR*

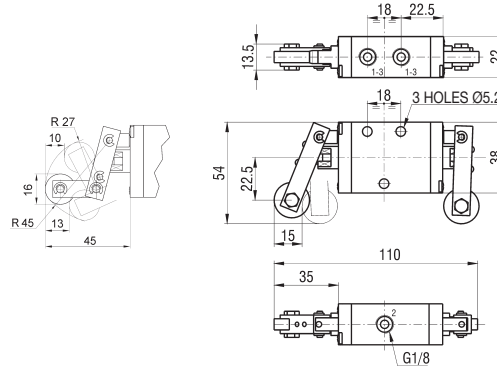

EKCA8/LR*

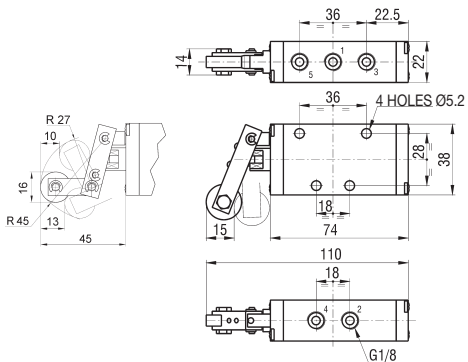

EKCA8/LRLR*

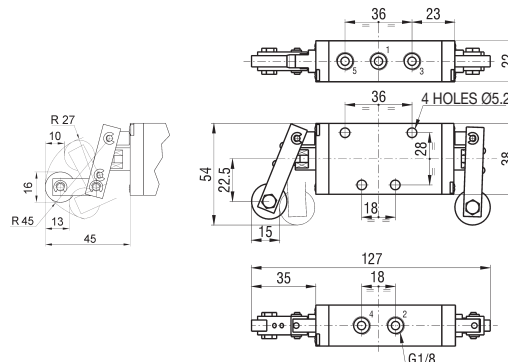

* - ADD THE LETTER "U" TO THE TYPE TO ORDER THE UNIDIRECTIONAL ROLLER VALVES - E.G.: EKCA8/LRLRU
 - ADD THE LETTER "N" TO THE TYPE TO ORDER THE VALVES WITH PLASTIC ROLLER - E.G.: EK8/LRN

EKA8/A - EKC8/A

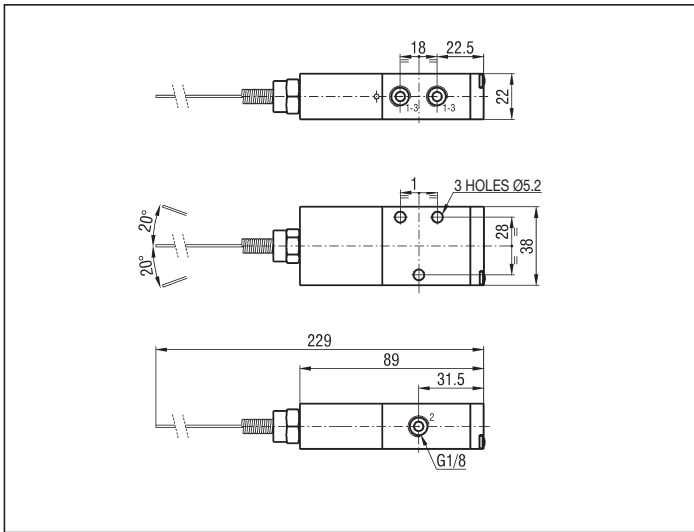

EKCA8/A

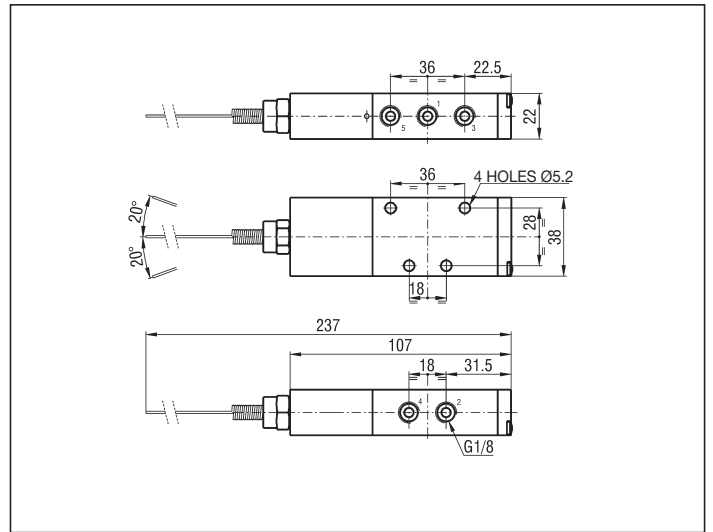

EKA8/TD - EKC8/TD*

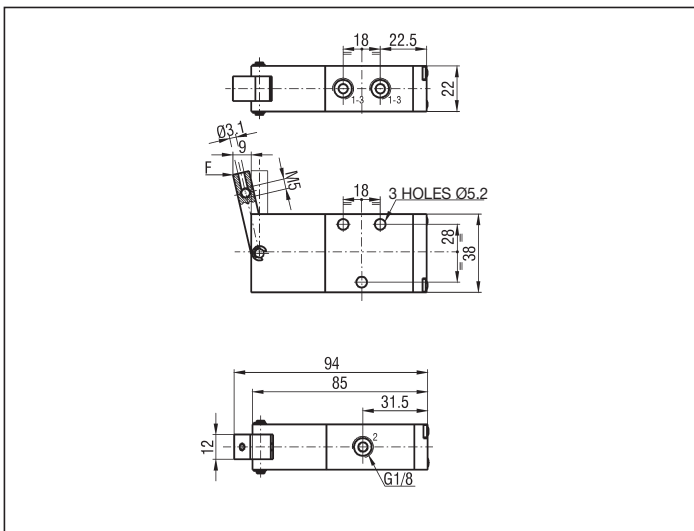

EKCA8/TD*

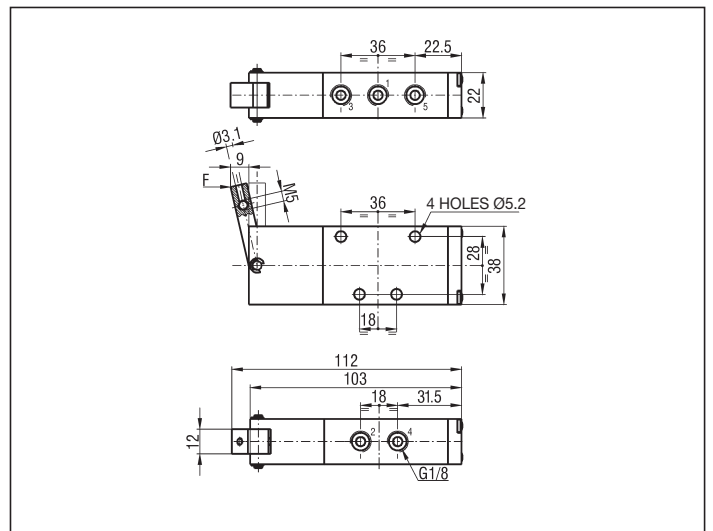

* IT IS POSSIBLE TO INCREASE THE SENSITIVITY OF THE KEY USING A Ø 3 mm EXTENSION ON THE SAME KEY

* IT IS POSSIBLE TO INCREASE THE SENSITIVITY OF THE KEY USING A Ø 3 mm EXTENSION ON THE SAME KEY

EKC8/Q - EKA8/Q

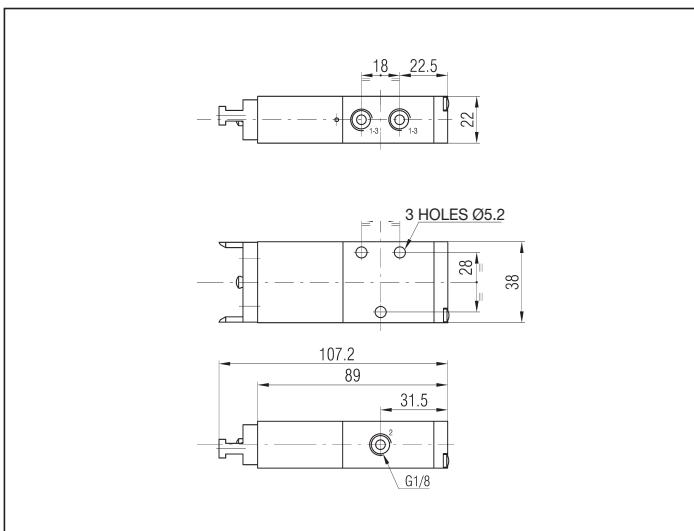

EKCA8/Q

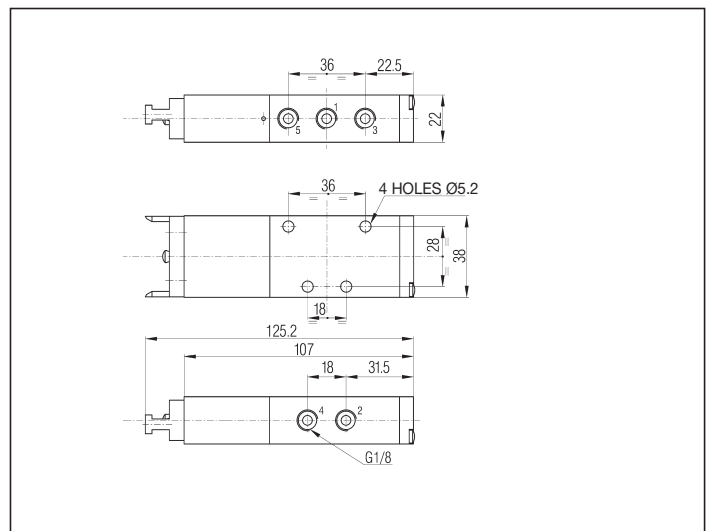

P.S.: SEE ACTUATORS FOR PANEL MOUNTING ON PAGE 3.6

P.S.: SEE ACTUATORS FOR PANEL MOUNTING ON PAGE 3.6

MANUALLY ACTUATED VALVES G 1/8

Symbol	Function	Controls		Flow rate at 6 bar $\Delta P = 1$ bar (l/min)	Weight (g)	TYPE
		Pilot	Return			
	3/2 N.O. monostable	Drawer	Mechanical spring	480	155	EK8/T
	3/2 N.C. monostable					
	3/2 bistable	Drawer	Drawer	480	155	EK8/TF
	5/2 monostable	Drawer	Mechanical spring	480	185	EKCA8/T
	5/2 bistable	Drawer	Drawer	480	185	EKCA8/TF
	3/2 N.O. monostable	Front lever	Mechanical spring	480	150	EK8/MV
	3/2 N.C. monostable					
	3/2 bistable	Front lever	Front lever	480	150	EK8/MVF
	5/2 monostable	Front lever	Mechanical spring	480	185	EKCA8/MV
	5/2 bistable	Front lever	Front lever	480	185	EKCA8/MVF
	3/2 N.O. monostable	Lateral knob	Mechanical spring	480	155	EK8/M
	3/2 N.C. monostable					
	3/2 bistable	Lateral knob	Lateral knob	480	185	EK8/MF
	5/2 monostable	Lateral knob	Mechanical spring	480	205	EKCA8/M
	5/2 bistable	Lateral knob	Lateral knob	480	205	EKCA8/MF
	5/3 monostable closed centre	Lateral knob	Mechanical spring	300	205	EKCA8/MS
	5/3 stable closed centre	Lateral knob	Lateral knob	300	205	EKCA8/MSF
	5/3 monostable open centre	Lateral knob	Mechanical spring	300	205	EKCA8/MA
	5/3 stable open centre	Lateral knob	Lateral knob	300	205	EKCA8/MAF

EK8/T - EK8/TF

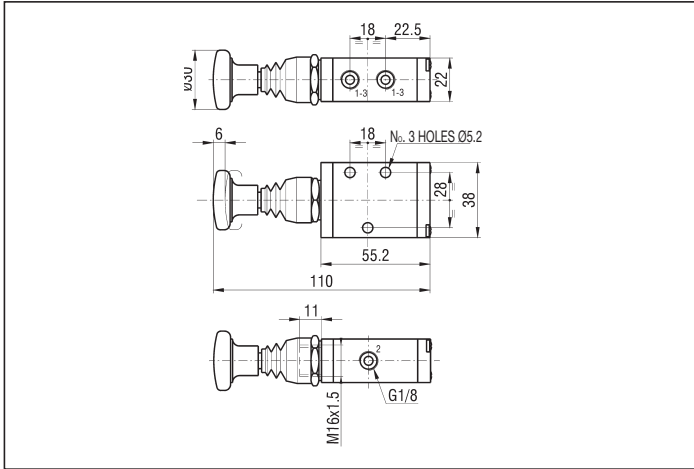

EKCA8/T - EKCA8/TF

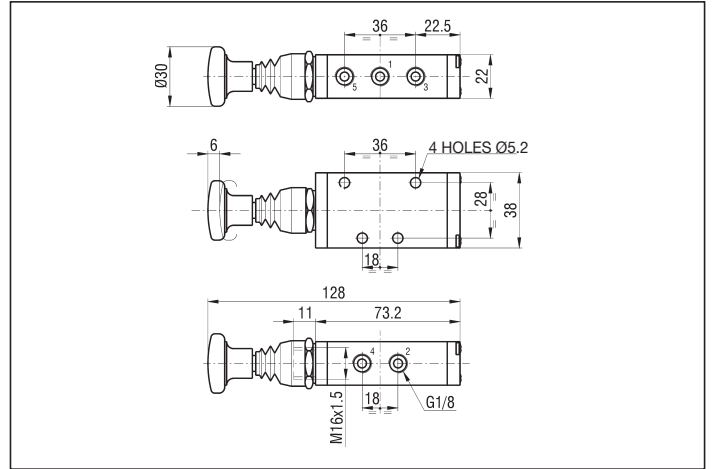

3

EK8/MV - EK8/MVF

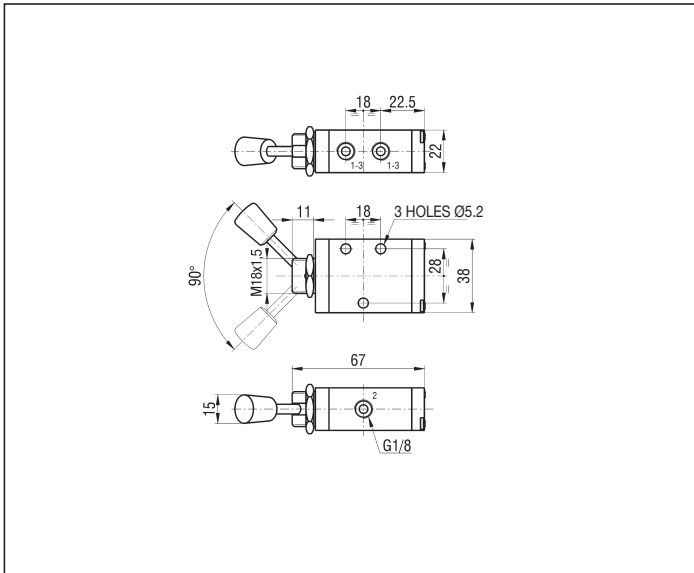

EKCA8/MV - EKCA8/MVF

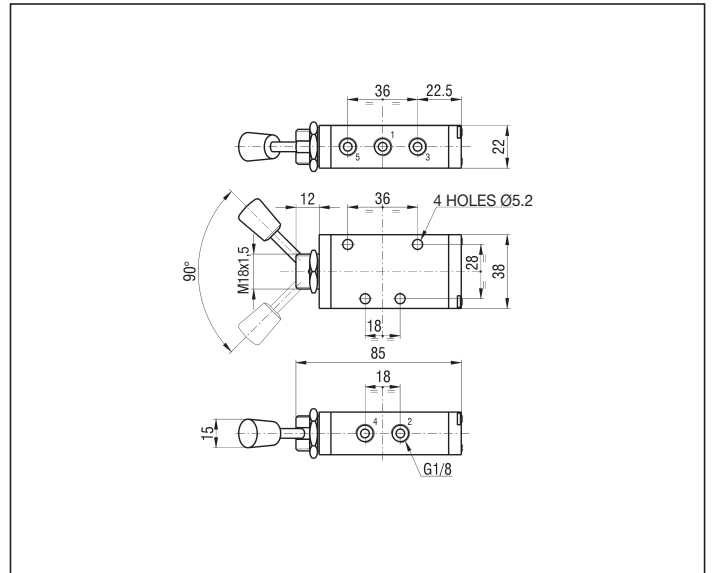

EK8/M - EK8/MF

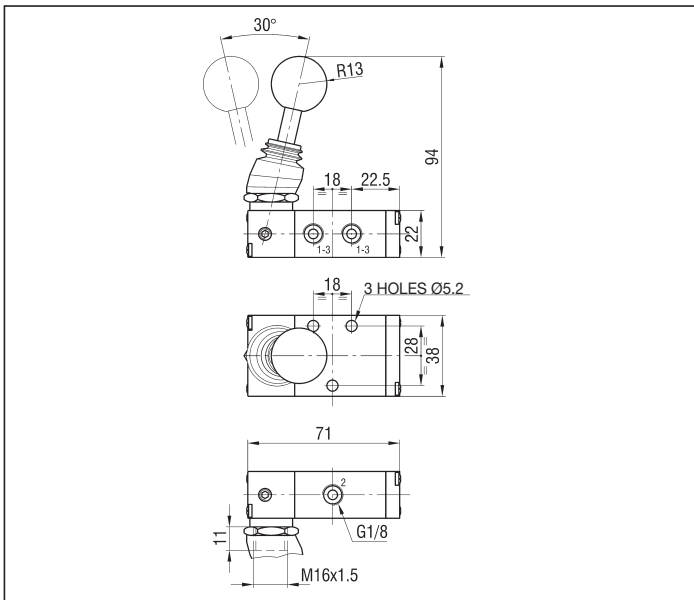

5/2 - 5/3 LATERAL KNOB

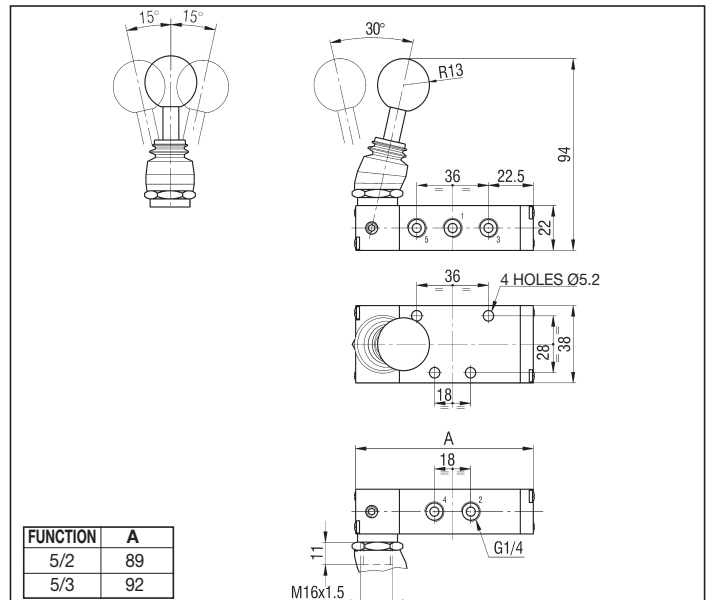

3

MECHANICALLY ACTUATED VALVES G 1/4

Symbol	Function	Controls		Actuation force at 6 bar (N)	Flow rate at 6 bar $\Delta P = 1$ bar (NI/min)	Weight (g)	TYPE
		Pilot	Return				
	3/2 N.O. monostable	Drawer	Mechanical spring	51	900	205	EK4/PS
	3/2 N.C. monostable						
	3/2 bistable	Drawer	Drawer	9,5	900	200	EK4/PSS
	5/2 monostable	Drawer	Mechanical spring	51	900	250	EKCA4/PS
	5/2 bistable	Drawer	Drawer	9,5	900	250	EKCA4/PSS
	3/2 N.O. monostable	Front lever	Mechanical spring	21	900	270	EK4/LR*
	3/2 N.C. monostable						
	3/2 bistable	Front lever	Front lever	16	900	325	EK4/LRLR*
	5/2 monostable	Front lever	Mechanical spring	21	900	320	EKCA4/LR*
	5/2 bistable	Front lever	Front lever	16	900	380	EKCA4/LRLR*

* ADD THE LETTER "N" TO THE TYPE TO ORDER THE VALVES WITH PLASTIC ROLLER - E.G.: EK4/LRN

EK4/PS

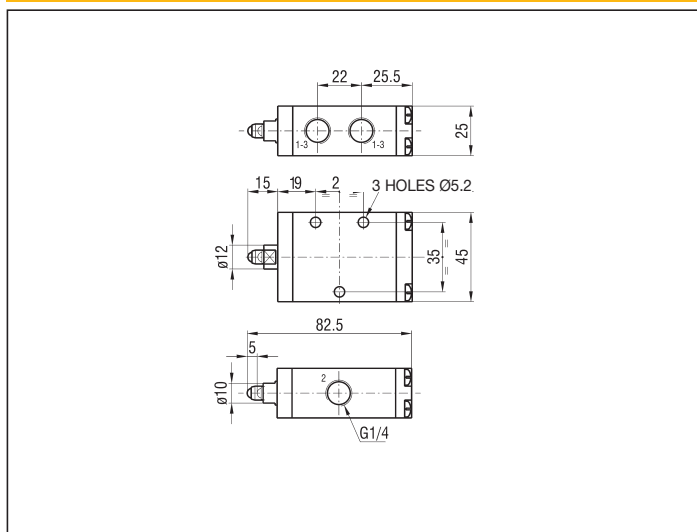

EK4/PSS

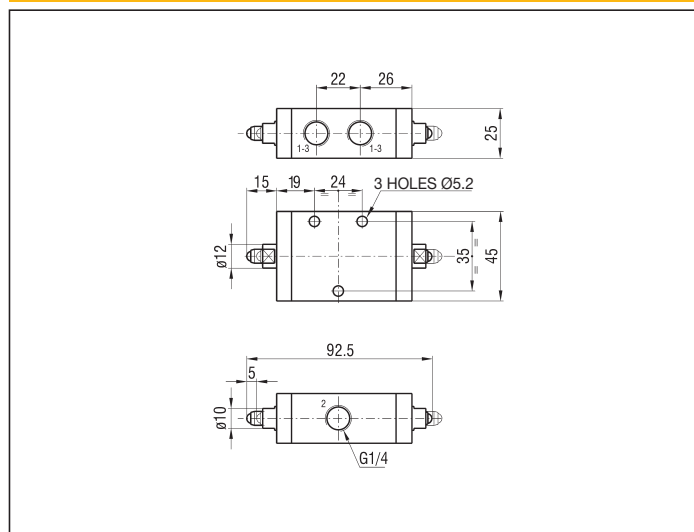

EKCA4/PS

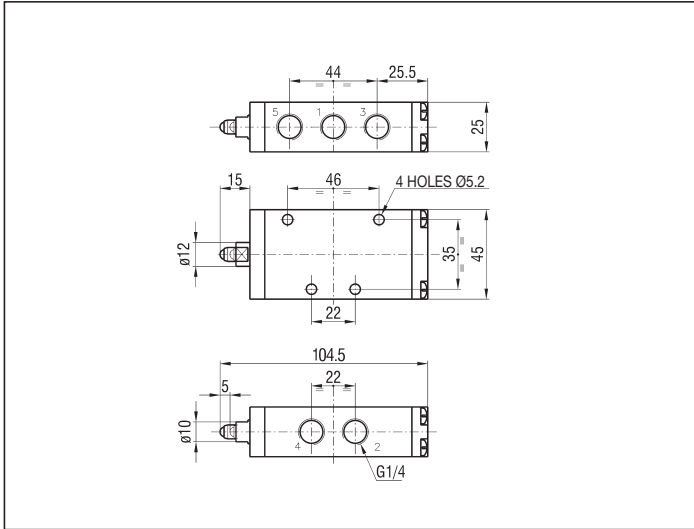

EKCA4/PSS

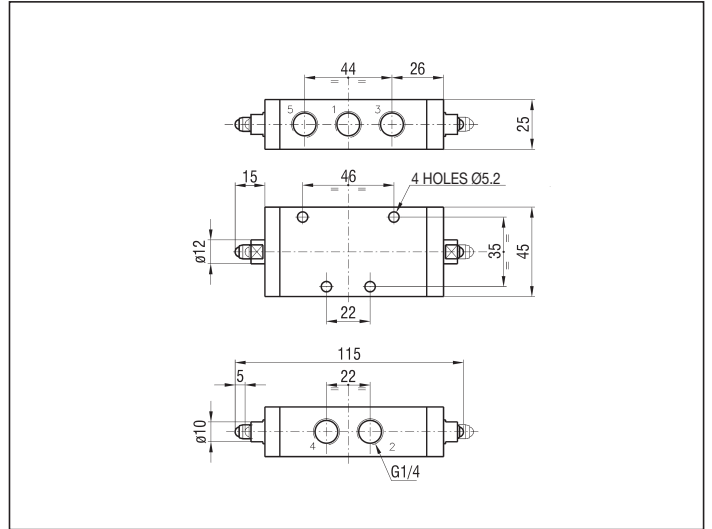

EK4/LR*

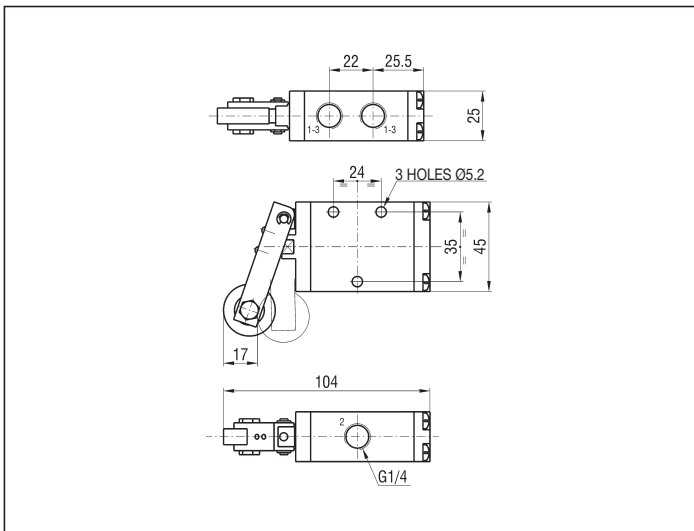

EK4/LRLR*

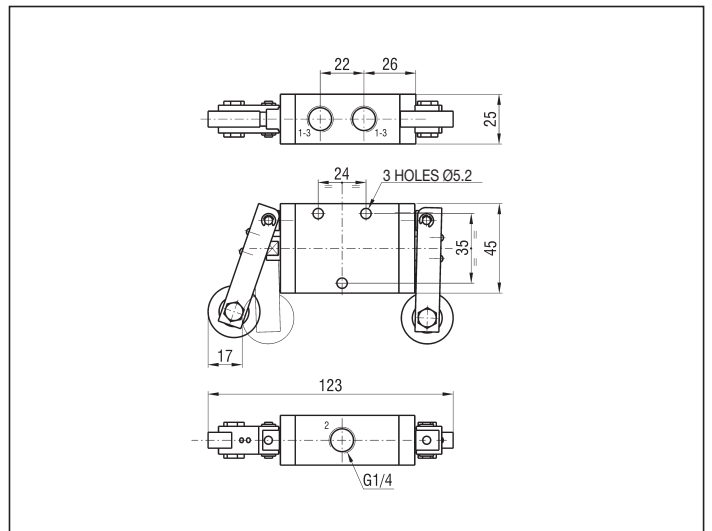

EKCA4/LR*

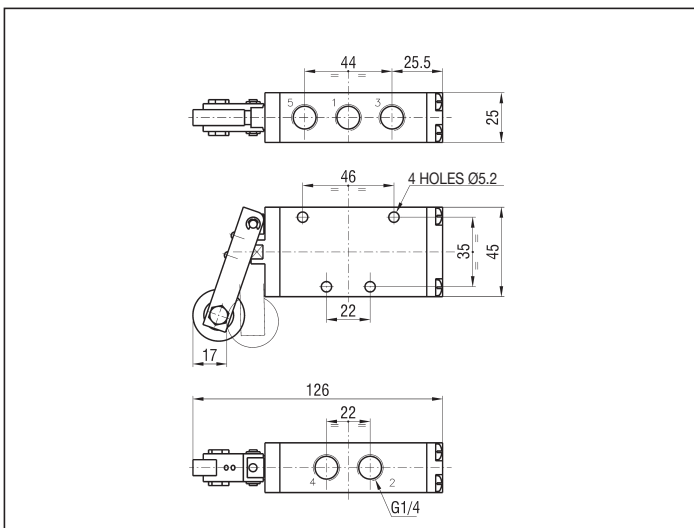

EKCA4/LRLR*

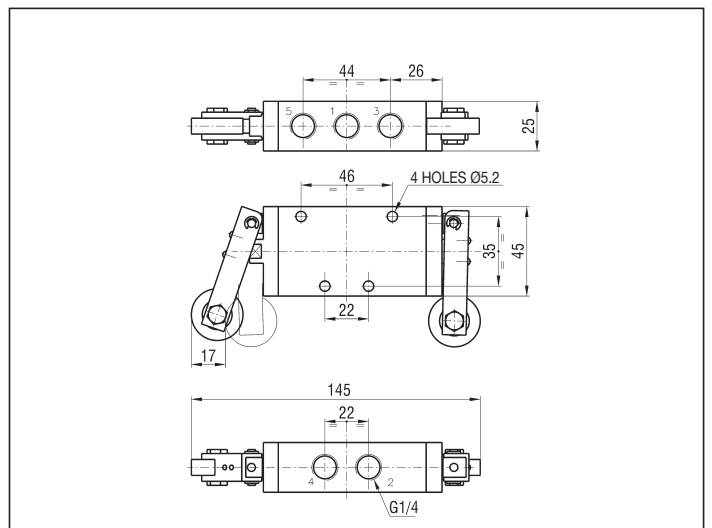

* ADD THE LETTER "N" TO THE TYPE TO ORDER THE VALVES WITH PLASTIC ROLLER - E.G.: EK4/LRN

3

MANUALLY ACTUATED VALVES G 1/4

Symbol	Function	Controls		Flow rate at 6 bar $\Delta P = 1$ bar (l/min)	Weight (g)	TYPE
		Pilot	Return			
	3/2 N.O. monostable	Drawer	Mechanical spring	900	240	EK4/T
	3/2 N.C. monostable					
	3/2 bistable	Drawer	Drawer	900	240	EK4/TF
	5/2 monostable	Drawer	Mechanical spring	900	305	EKCA4/T
	5/2 bistable	Drawer	Drawer	900	305	EKCA4/TF
	3/2 N.O. monostable	Front lever	Mechanical spring	920	230	EK4/MV
	3/2 N.C. monostable					
	3/2 bistable	Front lever	Front lever	920	230	EK4/MVF
	5/2 monostable	Front lever	Mechanical spring	920	185	EKCA4/MV
	5/2 bistable	Front lever	Front lever	920	185	EKCA4/MVF
	3/2 N.O. monostable	Lateral knob	Mechanical spring	920	255	EK4/M
	3/2 N.C. monostable					
	3/2 bistable	Lateral knob	Lateral knob	920	250	EK4/MF
	5/2 monostable	Lateral knob	Mechanical spring	920	310	EKCA4/M
	5/2 bistable	Lateral knob	Lateral knob	920	310	EKCA4/MF
	5/3 monostable closed centre	Lateral knob	Mechanical spring	780	310	EKCA4/MS
	5/3 stable closed centre	Lateral knob	Lateral knob	780	310	EKCA4/MSF
	5/3 monostable open centre	Lateral knob	Mechanical spring	780	310	EKCA4/MA
	5/3 stable open centre	Lateral knob	Lateral knob	780	310	EKCA4/MAF

EK4/T - EK4/TF

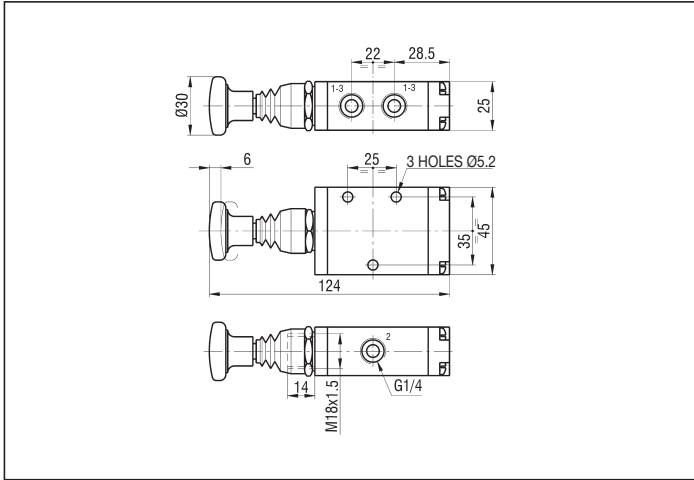

EKCA4/T - EKCA4/TF

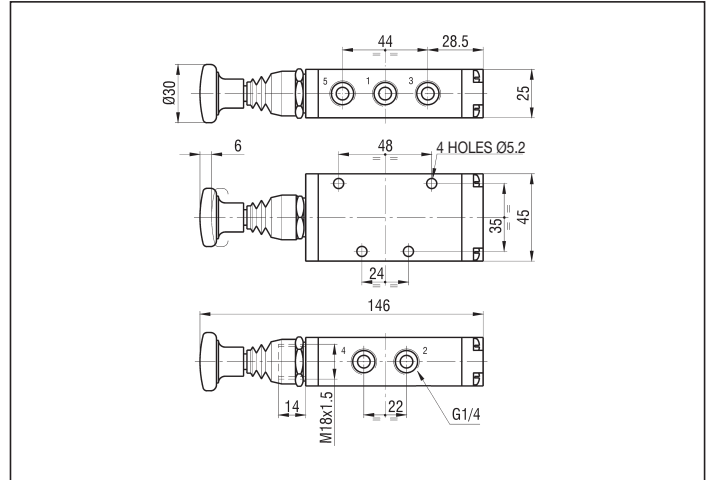

EK4/MV - EK4/MVF

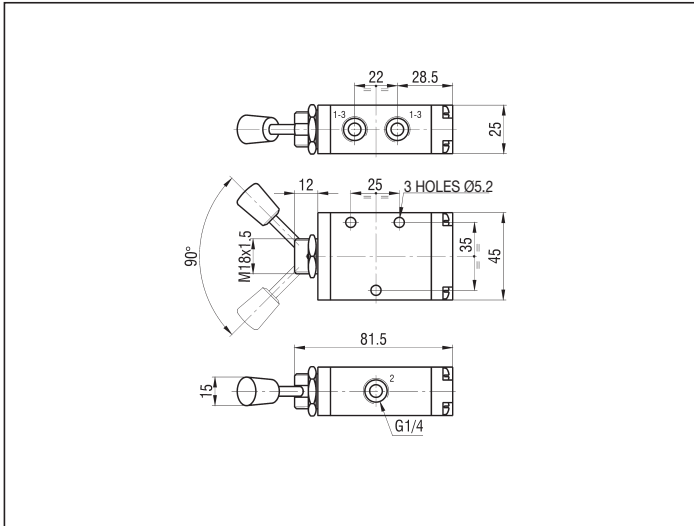

EKCA4/MV - EKCA4/MVF

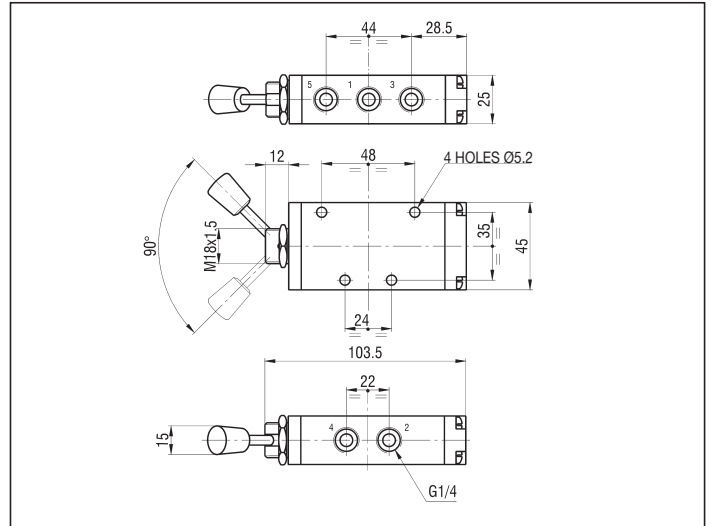

EK4/M - EK4/MF

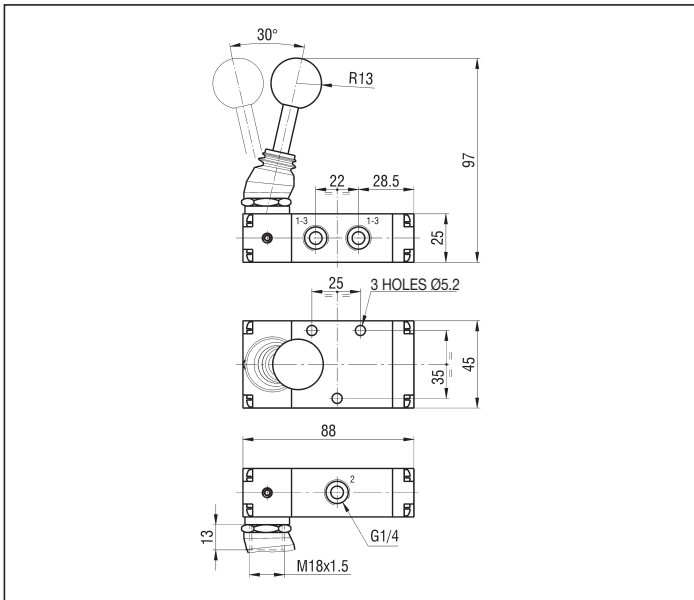

5/2 - 5/3 LATERAL KNOB

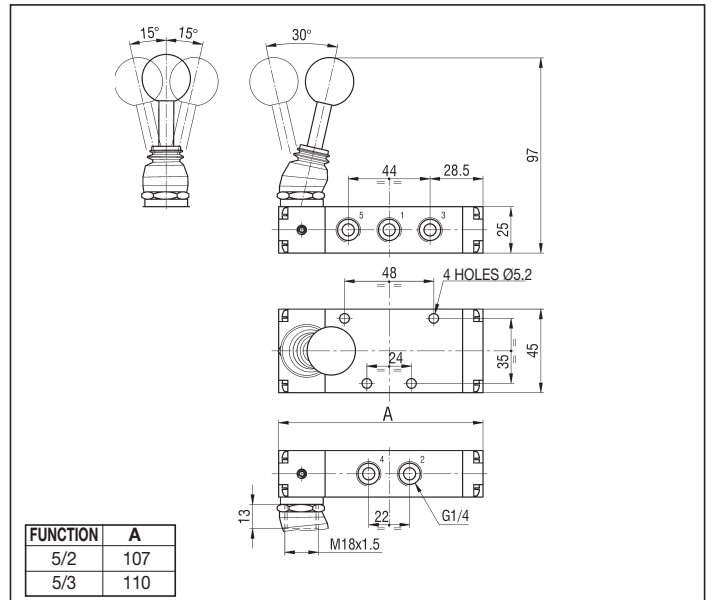

FUNCTION	A
5/2	107
5/3	110

MANUALLY ACTUATED VALVES G 1/2

Symbol	Function	Controls		Flow rate at 6 bar $\Delta P = 1$ bar (l/min)	Weight (g)	TYPE
		Pilot	Return			
	5/2 monostable	Lateral knob	Mechanical spring	2250	1200	EKCA2/M
	5/2 bistable	Lateral knob	Lateral knob	2250	1200	EKCA2/MF
	5/3 monostable closed centre	Lateral knob	Mechanical spring	2000	1200	EKCA2/MS
	5/3 stable closed centre	Lateral knob	Lateral knob	2000	1200	EKCA2/MSF
	5/3 monostable open centre	Lateral knob	Mechanical spring	2000	1200	EKCA2/MA
	5/3 stable open centre	Lateral knob	Lateral knob	2000	1200	EKCA2/MAF

5/2 - 5/3 LATERAL KNOB

