

# Stainless steel Cylinders to ISO 6432 standard

# series AU

## DESCRIPTION

Calked stainless steel cylinders series "AU" comply with ISO 6432 standard. They're are available from Ø 16 to Ø 25, magnetic and non-magnetic and in the adjustable cushions version produced from Ø 20 to Ø 25.

They are also available in the version to ATEX directive, 2GD category.

## TECHNICAL DATA

Operating pressure	1+10 bar
Working temperature	0°C ÷ +80°C (with dry air -35°C) 0°C ÷ +150°C with VITON® seals (with dry air -10°C)
Fluid	Filtered, unlubricated or continuous lubricated compressed air
Versions	Double acting; Through rod
Bore	Ø 16, 20, 25
Port size	Ø 16 = M5 Ø 20 - 25 = G 1/8
Standard strokes (mm)	25, 50, 80, 100, 125, 160, 200, 250, 300, 320, 400, 500
Decelerators lenght	Ø 20 25 mm 18 20
Maximum strokes (mm)	Ø 16 = 200; Ø 20 = 320; Ø 25 = 500



## MATERIALS

End caps	AISI 304 stainless steel
Cylinder barrel	Extruded tube, AISI 304 stainless steel
Barrel-end cover fixing type	Irreversible calking with dual-seal system, mechanical and pneumatic
Piston rod	AISI 316 stainless steel
Rod nut and ring nut	AISI 304 stainless steel
Decelerator ogives	Aluminium alloy
Piston rod bearing	Self lubricating sintered bronze
Piston	Brass (supplied with and without magnet)
Seals	Polyurethane - VITON®

## ORDER KEY

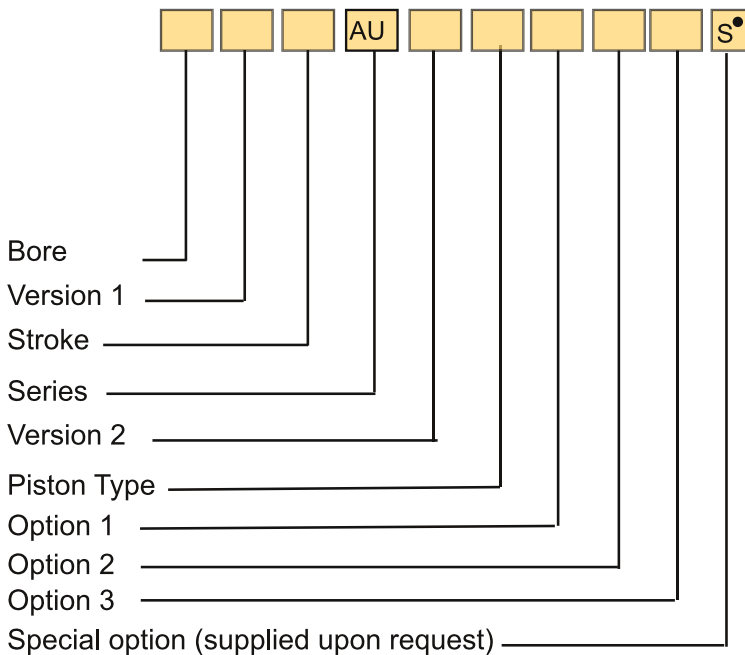

## VERSION 1

/ Basic cylinder **R** Through rod

## VERSION 2

**D** Double acting

## PISTON TYPE

**C** Non-magnetic

**E** Magnetic\*

## OPTION 1

**X** Cushioned\*\*

## OPTION 2

**2** VITON® seals

## OPTION 3

**/EX** Complies with the ATEX directive

**Ex** II 2GDc T5 T100°C -20°C<Ta<80°C

\* It's possible use it with VITON® seals for applications with chemical compatibility; It's not supplied for with high temperature applications.

\*\* Supplied for Ø20 and Ø25

P.S.:Magnetic sensor FM100-FM157 (see chapter magnetic sensor from page 1.93 CAT.08/IT)

● See technical data on page 0.12 CAT.08/IT

## ORDER EXAMPLES

Basic cylinder Ø 16, 50 mm stroke, double acting, non-magnetic piston type, ATEX: **16/50 AUDC/EX**

Basic cylinder Ø 20, 50 mm stroke, double acting, non-magnetic piston type, cushioned: **20/50 AUDCX**

Cylinder Ø 25, through rod, 100 mm stroke, double acting, magnetic piston type, cushioned: **25R100 AUDEX**

### AU BASIC CYLINDER

1

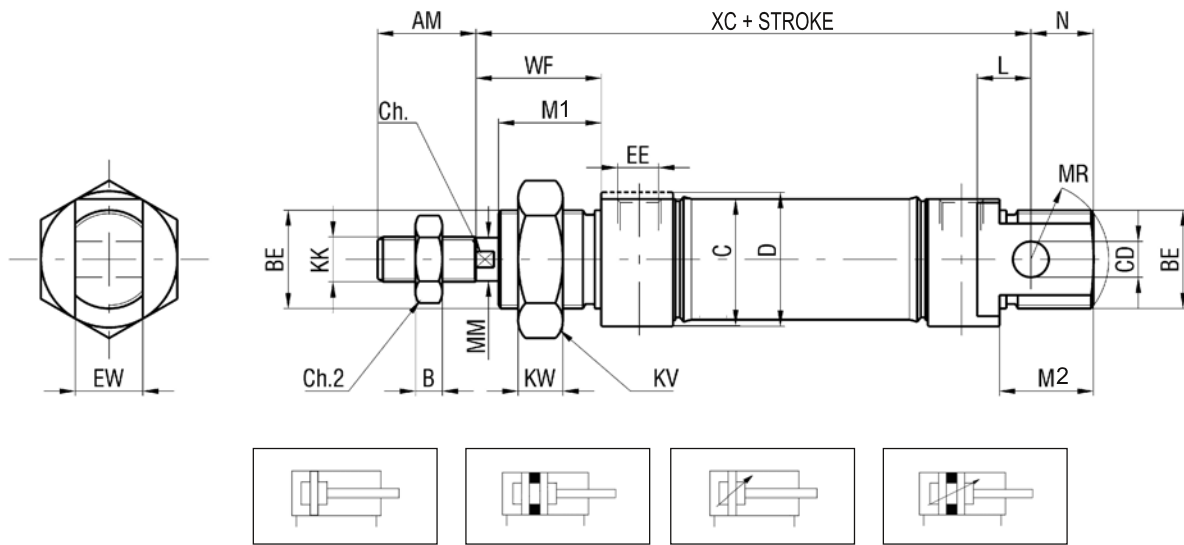

P.S.: End cap nut and rod nut supplied as standard

### DIMENSIONS AND WEIGHTS BASIC CYLINDER

∅	AM*	B	BE*	C	CD* H9	Ch*	Ch2	D*	EE*	EW* d13	KK	KV	KW*	L*	M1	M2	MM	MR*	N	WF*	XC*	WEIGHT (g)	INCR.(g) x 10 mm
16	16	4	M16X1,5	18	6	5	10	19	M5	12	M6	22	5	9	18	18	6	13.3	11	22	82	139	4.9
20	20	5	M22X1,5	25.5	8	7	13	27	G1/8	16	M8	27	8	12	20	20	8	18.8	16	24	95	306	7.2
25	22	6	M22X1,5	28.5	8	9	17	30	G1/8	16	M10X1.25	27	8	12	22	22	10	17.1	14	28	104	406	11

\* STANDARDIZED DIMENSIONS

### THROUGH ROD

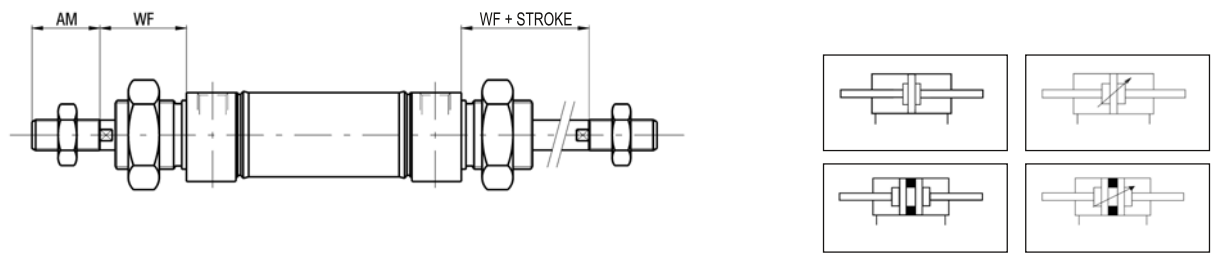

P.S.: End cap nuts and rod nuts supplied as standard

# Accessories

## AISI 304 stainless steel fixing for cylinders to ISO 6432 standard

# series AU

### END CAP NUT - STAINLESS STEEL - UPDT Ø

Ø	DI	CH	S	WEIGHT (g)
16	M16X1,5	24	8	16
20-25	M22X1,5	32	11	25

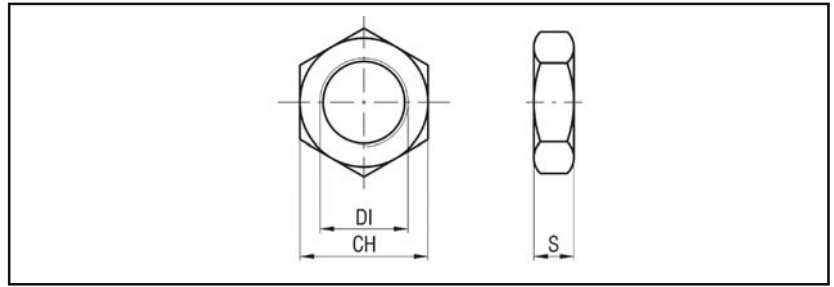

### FLANGE - STAINLESS STEEL - UPF Ø

Ø	FB H13	LW	S	TF JS13	UF	UR	WEIGHT (g)
16	5.5	18	4	40	52	30	10
20	6.6	19	5	50	66	40	20
25	6.6	23	5	50	66	40	20

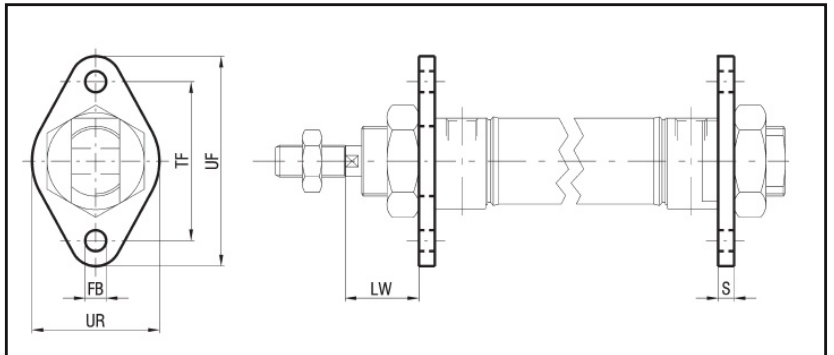

### FOOT - STAINLESS STEEL - UPP Ø

Ø	AB H13	AU	LA	LB	LC	NH	R
16	5.5	14	20	74-81	28-35	20	12,5
20	6.6	17	25	91	45.5	25	20
25	6.6	17	25	95	45.5	25	20

Ø	S	TR JS13	US	XS	XT	WEIGHT (g)
16	4	32	42	32	8	25
20	5	40	54	36	7	40
25	5	40	54	40	11	40

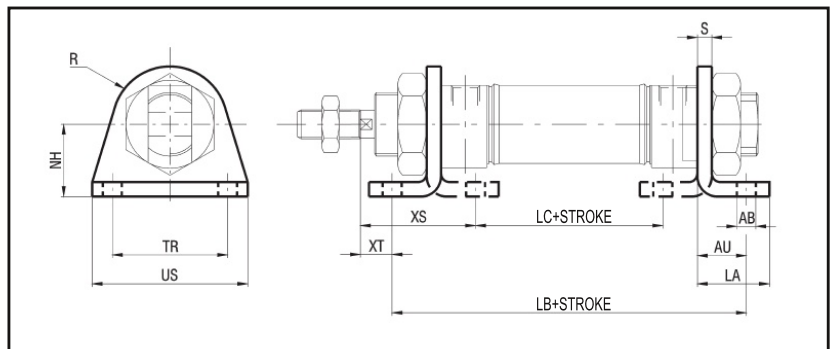

### REAR HINGE - STAINLESS STEEL - UPSC Ø

Ø	CD f8	D H13	H	LA	LB JS13	LC E9	LD
16	6	5.5	27	25	15	12.1	5
20	8	6.6	30	32	20	16.1	6
25	8	6.6	30	32	20	16.1	6

Ø	LE	LX	R	S	WEIGHT (g)
16	23	80	7	3	36
20	29,5	91	10	4	78
25	29,5	100	10	4	78

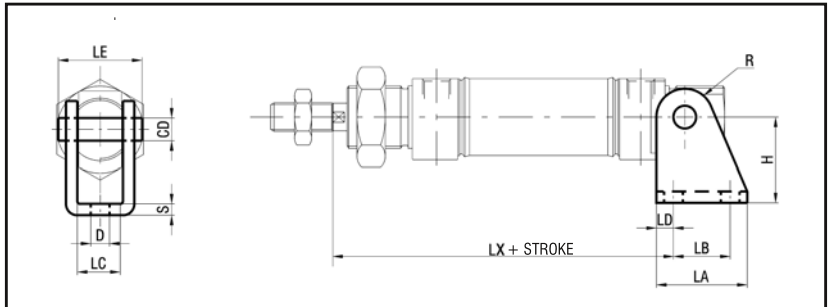

### FEMALE PISTON ROD CLEVIS WITH PIN AND SNAP RING TO ISO 8140 - STAINLESS STEEL - A/FFP\_\_

∅	DA	DB	DE	F b12	G	HA	HB	L	WEIGHT (g)	TYPE
16	M6	10	6	6	12	12	24	31	20	A/FFP6
20	M8	14	8	8	16	16	32	42	44	A/FFP8
25	M10X1.25	18	10	10	20	20	40	52	85	A/FFP10X1.25

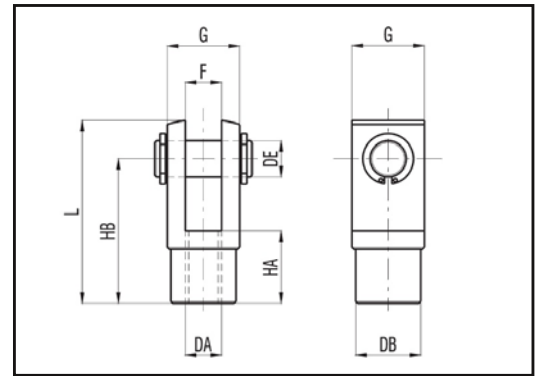

### ROD NUT - STAINLESS STEEL - DSTI\_\_

∅	DI	CH	S	WEIGHT (g)	TYPE
16	M6	10	4	1.48	DSTI6
20	M8	13	5	4	DSTI8
25	M10X1.25	17	6	8	DSTI10X1.25

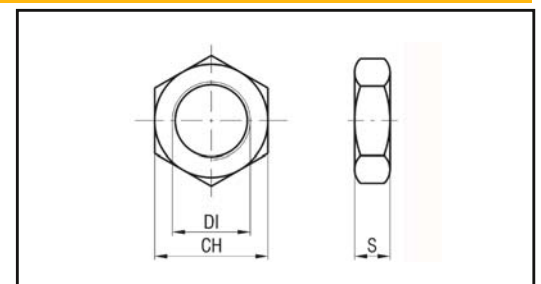

### MAGNETIC SENSORS SERIES FM100 - FM157

See chapter magnetic sensors FM series from page 1.93 CAT.08/IT

### MAGNETIC SENSORS FIXING SERIES FM100 - FM157

#### FM100 MAGNETIC SENSOR FIXING ADAPTER - PLASTIC - FG∅

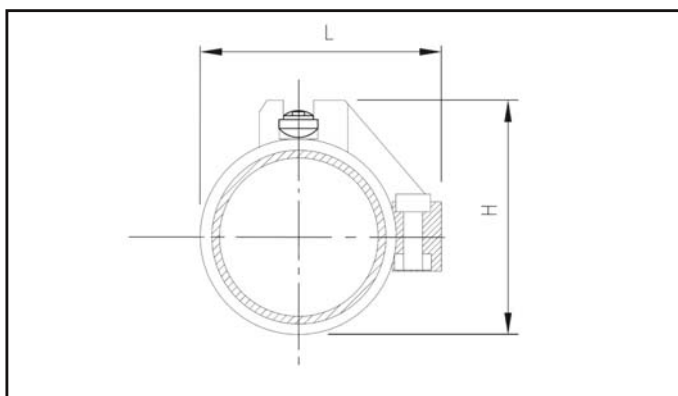

∅	H	L	TYPE
16	26	28	FG16
20	27	29	FG20
25	36	38	FG25

#### FM157 MAGNETIC SENSOR FIXING ADAPTER - PLASTIC - FG/\_\_\_

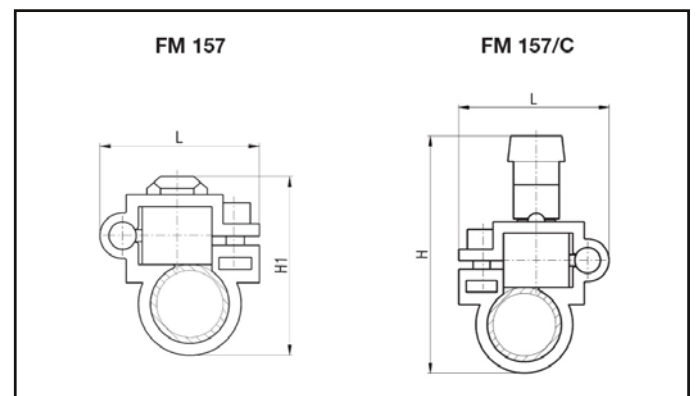

∅	H1	H	L	TYPE
16	33	45	28.5	FG/053
20	38	52	32	FG/054
25	43	58	32	FG/055